



AMP-119D.MF

Fire Extinguishing System For Mixer

User manual

(Version 2.**)

AMPE TECHNOLOGY CO.,LTD

www.ampecn.com

P r e l u d e

Thanks for using new models AMP series of high performance metal & spark diverter produced by Ampe Technology Co., Ltd. AMP series products are manufactured with high quality units, materials and with the utilization of latest microcomputer technology. Ampe Technology Co., Ltd. continuously practices the design and innovation of the product and provides excellent products with professional attitude. Furthermore, it responds to the customers with professional service and benefits each other with the customers.

The manual provides cautions about the installation, parameter setting, troubleshooting and daily maintenance of metal & spark diverter to the user. In order to assure the proper installation and usage of the product, please read this manual in detail before installation. Please keep the manual well and give it to the operator of the machine.

Welcome to visit the website of Ampe Technology Co., Ltd. : www.ampecn.com. The website provides the download of the operation instructions and technical BBS service.

The following are the cautions that need special attention:

ATTENTION!

1. First please carry out the delivery inspection and check whether there is damage caused by transportation process.
2. After unpacking, please compare with the packing list and check the type, specification and components of the product. If it does not conform to your order documents or if you have any questions regarding the product, please contact to the dealer or the service office of our company.
3. Ampe Technology Co., Ltd. provides services of the three guarantee period 18 months from the delivery date.
4. Troubles due to lightening strike, water invasion and obvious artificial miss or damage etc. are not in the range of repair guarantee.
5. Metal & spark diverter series products are important products of the fore-spinning procedure in cotton spinning mill. But the users in cotton spinning mill should also take integrated measures in fire protection equipments, selection of material, management regulations etc. to assure the safety production.

CAUTION !

1. The power supply must first be shut down before the electric wiring.
 2. Wiring, repairing & maintenance of the machine should be carried out by electric professionals.
 3. Do not carry out compression test toward the inner components because the semiconductor units are easy to be broken down by the high voltage and are easy to damage.
 4. The circuit board CMOS integrated circuit is apt to static electricity damage. So you should take the static electricity prevention measure before touching the circuit board with hand.
 5. As the machine is installed to the pipe in high place, installation personnel should take safety measures. Suspending or bracket should be solid to prevent the machine from dropping down.
 6. Select safety area to install the equipment, prevent the high temperature & direct shinning and avoid humidity and splashing of the water drops.
-

Contents

A. Overview.....	2
1. Use and structural characteristics	2
2. Technical parameter	3
B. Electric wiring and installing	3
1. Installing	3
1.1 The host machine	3
1.2 Spark detectors.....	4
1.3 AMP-119DC flap valve	5
1.4 119DCS-III extinguisher	6
2. Electric wiring.....	6
2.1 Wiring instructions of the control box	6
2.2 Wiring and usage of 119D-SD spark detectors	7
3. Working principle	8
4. Grounding and safety	9
C. Debugging and usage maintenance	9
1. Indicative and adjustable parameter of the control panel.....	9
1.1 Displays of the panel.....	9
1.2 The fire alarm page	10
1.3 The description of keys.....	10
2. Parameter setting.....	11
2.1 Real time set.....	11
2.2 System set	11
2.3 History	12
2.4 Communication.....	12
2.5 About machine page.....	13
3. Fire alarm simulation test.....	13
D. Communication	14
1. Communication baud rate and address setting	14
2. Communication protocol	14
2.1 Communication format	14
2.2 Communication protocol RTU mode.....	14
2.3 Local communication protocol parameters address definition	14
E. Troubleshooting.....	16

A. Overview

1. Use and structural characteristics

AMP-119D.MF Fire Extinguishing System For Mixer is specially used for fire protection for multi-mixer. When the fire be detected, the system will automatically open the CO₂ extinguishing system to protect the raw materials and mixer. Once a spark is detected, it can quickly alarm, stop the fan, and extinguish the fire through extinguishing media to prevent the fire from spreading to the next process. It is a fireproofing equipment of easy installation, flexibility configuration, safety use and adapting to any environment.

The equipment consists of the host machine, spark detectors, flap valve, extinguisher.

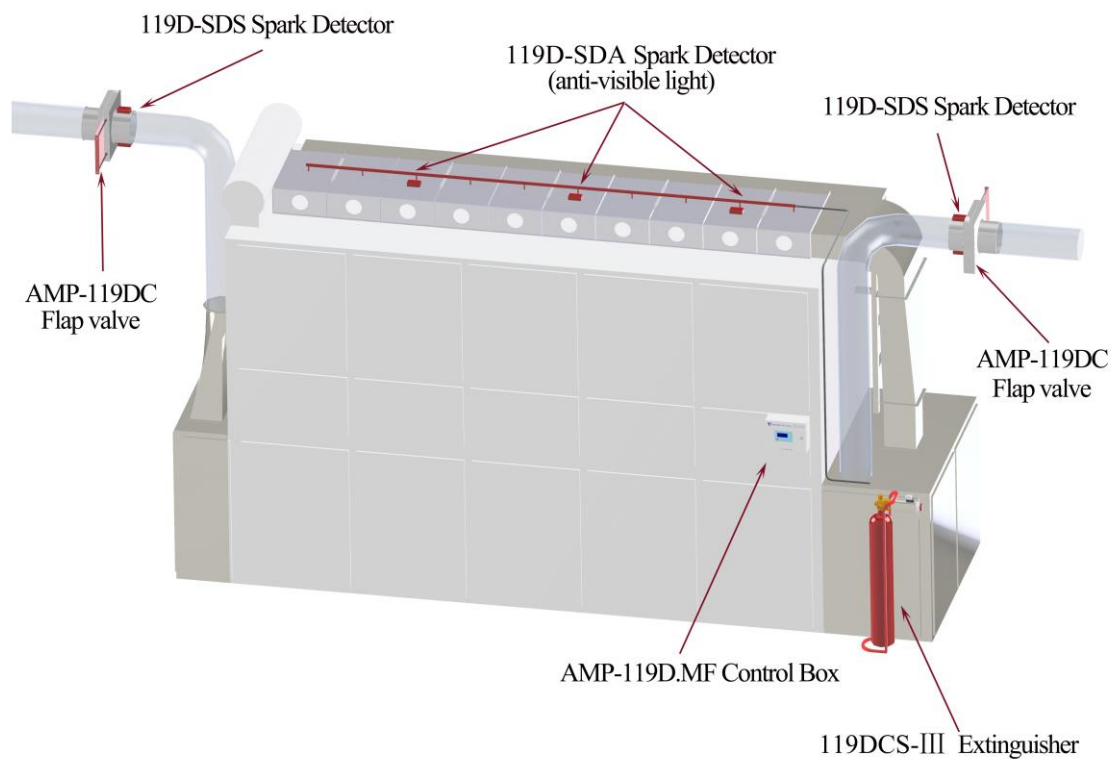

Figure 1: Installation of AMP-119D.MF fire extinguishing system for mixer

AMP-119D.MF fire extinguishing system for mixer has the functions as follows:

- 1) It takes leasing mechanism of host machine and spark detectors, the system is equipped with 5 spark detectors.
- 2) The 119D-SDS spark detectors configured on both sides of the pipeline is the main secondary detectors, and the spark detectors configured on the top of the mixer is the 119D-SDA type anti visible light spark detector, which adopts infrared sensing method, with high sensitivity, fast response speed, wide detection range, and stable operation.
- 3) The spark detectors and host machine are taking the power wave communication. They can be connected with only two wires and the transferring distance is long, it's easy

and dependable.

4) The host is equipped with a LCD display, it will store the alarming time automatically beside showing the alarming area.

5) This system is equipped with two AMP-119DC flap valves and a set of 119DCS-III extinguisher to achieve fire extinguishing function.

6) RS485 communication interface, Modbus communication protocol; It can be connected to AMPE IoT to achieve remote control of apps and WeChat platforms.

2. Technical parameter

1) Sensitivity : Bigger than $\Phi 0.5\text{mm}$ spark, visual angle is no less than 90°

2) Response time: $<300\text{ms}$

3) Power supply: 100-240VAC

4) Fire extinguishing medium capacity: 42kg

5) Extinguishing medium spraying time : $\geq 150\text{s}$

6) Gas pressure range: 600 ~ 800Kpa

7) Output relay contact load: DC24V

8) Sound level of alarm: $>100\text{db}$

9) Requirement of the environment: Temperature $-10^\circ\text{C}—70^\circ\text{C}$, relative humidity $20\% \sim 70\% \text{RH}$

B. Electric wiring and installing

1. Installing

When installing and working with the equipment, please be sure to have read and understood all the user instructions, for the correct electric wiring and installing are important.

1.1 The host machine

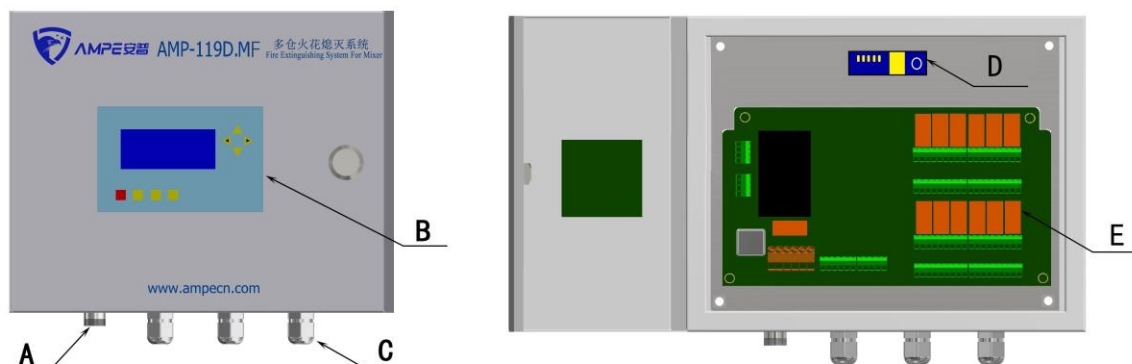

A. BNC B. Operation panel C. Pipe joint for wire threading

D. DTU(Optional for customers) E. Control board

Figure 2: The host machine

1) The host machine is usually hung by wall, fixed with M6 expansion screws. Please install this equipment at the obvious place, so that it would be found by the operators on duty upon the fire alarms.

2) The host machine has displays of fire-alarm area and real time, as well as the alarm buzzer equipped. It will alarm with sound and light as well as shows the correct alarming address after the host machine decodes the signal from the alarming detector. Output relay signals controlling the work of the corresponding fans or the whole production line as well as driving the trash removal mechanism to extinguish a fire, press the RESET key to return the machine to the normal, meanwhile, the latest alarm-message would be saved.

1.2 Spark detectors

This system is equipped with two sets of 119D-SDS spark detectors and three 119D-SDA anti visible light spark detectors.

1) Before installing the 119D-SDA anti visible spark detector, A hole of $\Phi 22\text{mm}$ (it should be round, smooth without burry-feeling) is needed to be drilled on the top of the mixer , detector installation hole requires the inner and outer edges of the hole to be smooth and free of burrs. when install the detector, make it to aim at the hole. The detectors can adsorb on the metal pipe for the strong magnetic.

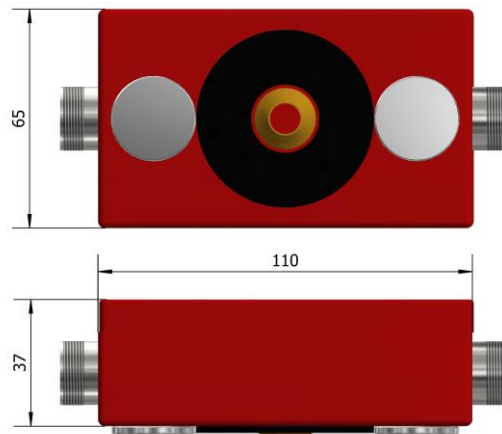

Figure 3: Diagram of spark detector

2) The power lines of detectors should be shielded cables with two-core to prevent the interference signals, and the two-core shielded cables should be protected by collars to avoid being short. By the way, the soldered plugs should be also connected to BNC reliably.

3) Pay attention to avoid direct shining or reflecting from the sun into the inspection area, otherwise it may trigger false alarms.

4) The alarming signals of detector transfer the current carrier by the method of code

modulation, and each detector works separately. Detectors can be series or parallel connection, and that is flexible. The code address of detector is carried out by five-binary system of coding in itself (see table 1 in this chapter).

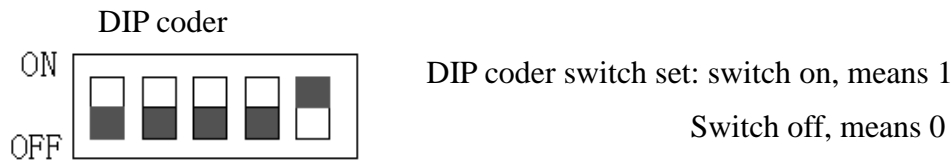

Switch set	NO.	Switch set	NO.		Switch set	NO.	Switch set	NO.
00000	0	01000	8		10000	16	11000	24
00001	1	01001	9		10001	17	11001	25
00010	2	01010	10		10010	18	11010	26
00011	3	01011	11		10011	19	11011	27
00100	4	01100	12		10100	20	11100	28
00101	5	01101	13		10101	21	11101	29
00110	6	01110	14		10110	22	11110	30
00111	7	01111	15		10111	23	11111	31

Table 1: Coder switch set

1.3 AMP-119DC flap valve

This system is equipped with two sets of AMP-119DC flap valves, which are installed on the pipes at the inlet and outlet of mixer.

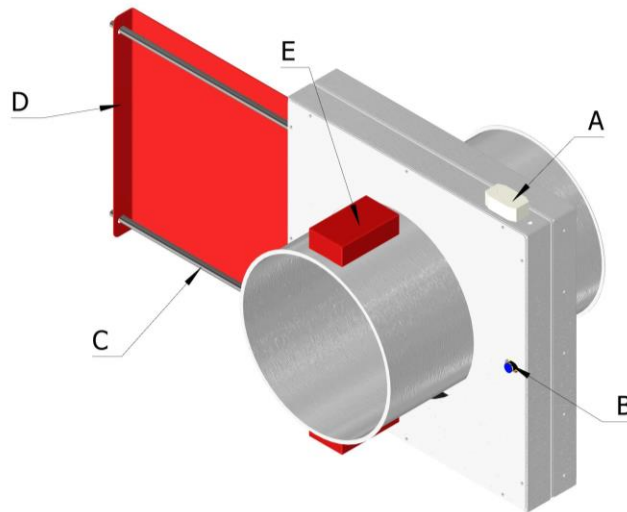

A. Junction box B. $\Phi 8$ mm joint C. Cylinder D. Flap E. 119D-SDS spark detector

Figure 4: Introduction of AMP-119DC flap valve

1.4 119DCS-III extinguisher



A. Solenoid valve B. Tracheal joint

Figure 5: Introduction of 119DCS-III extinguisher

2. Electric wiring

2.1 Wiring instructions of the control box

1) Electrical wiring of P7 terminal

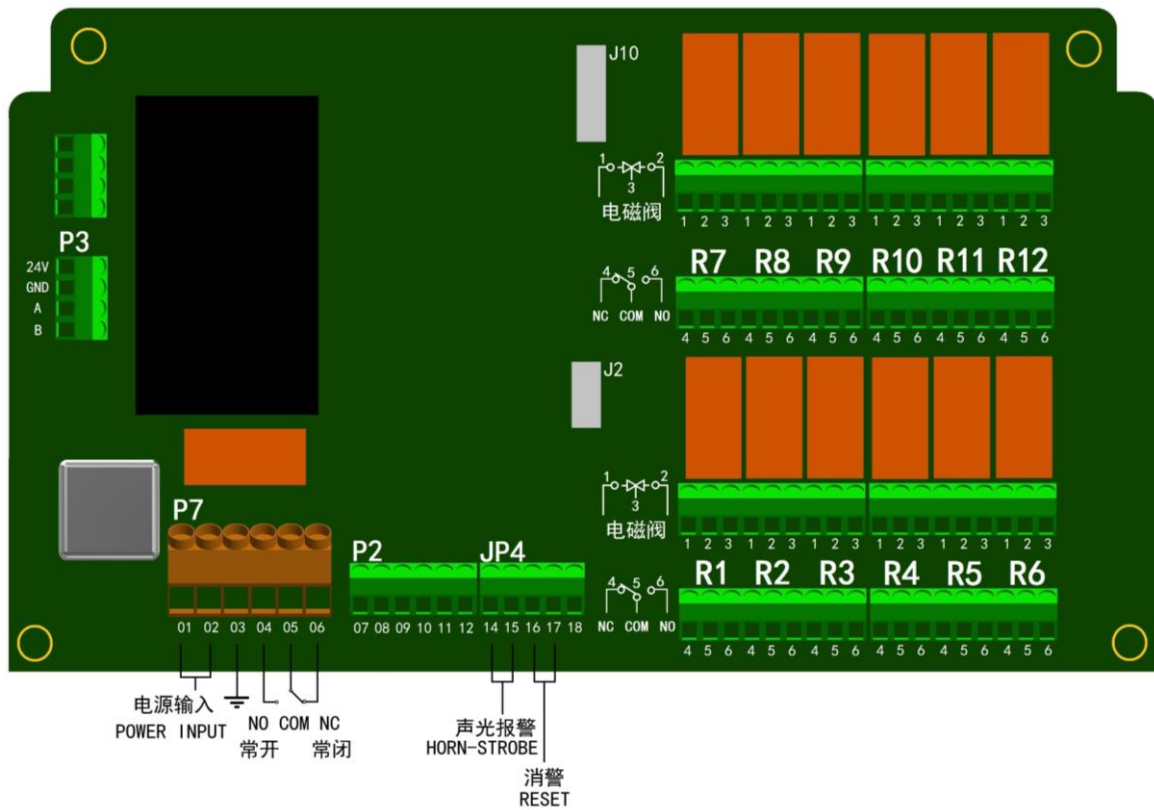

Figure 6: Inner of the control box

a. Terminal 01 and 02 of P7 are power input, terminal 03 is ground electrode.

⚠ ATTENTION

1. The power supply should be avoided being cut off when spark alarm stopping happens;

2. The power supply wiring should come from power distribution cabinet in the workshop, do not use AC220V from control transformer of the electrical control cabinet. We shall avoid the share of power supply with other equipment that may produce interference radiation, such as high-power inverter and motor's frequent start-stop. Please provide separate power supply if possible.

b. Terminal 04 "NO", 05 "COM" and 06 "NC" are a group of passive relay contact output. The relevant equipment can be shut off when spark alarm happens.

2) Electrical wiring of P2 terminal

Terminals 07, 08, 09, and 10, 11, and 12 are two sets of spark detectors interfaces.

3) P3 is the 485 communication interface.

4) Electrical wiring of JP4 terminal

a. Terminal 14 and 15 are connected to sound and light alarm signal, terminal 14 is connected to positive pole, terminal 15 is connected to negative pole.

b. Terminal 16 and 17 are connected with external alarm elimination keys.

5) J10 terminal is a reserved output relay extension interface.

6) J2 terminal is a DTU interface.

7) This machine has a total of 12 executive output relays, every relay provides a set of passive normally open and normally closed output points (contact capacity 3A, 220VAC) and a set of 24V solenoid valve outputs.

When a spark alarm occurs, the R1~R6 relays act. Terminals 1 and 3 of the R1 and R2 relays are connected to the AMP-119DC flap valve at the inlet and outlet of the mixer. The R3 relay is connected to the solenoid valve of the 119DCS-III extinguisher. R4~R6 are reserved relays that can drive other devices.

2.2 Wiring and usage of 119D-SD spark detectors

Host machine DC24V

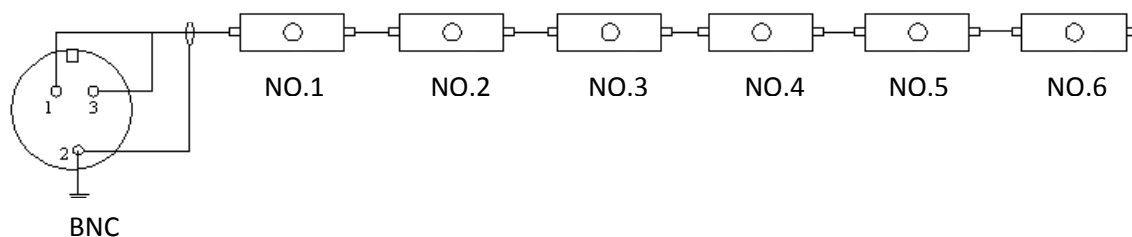

Figure 7a: Connecting diagram of spark detectors

Host machine DC24V

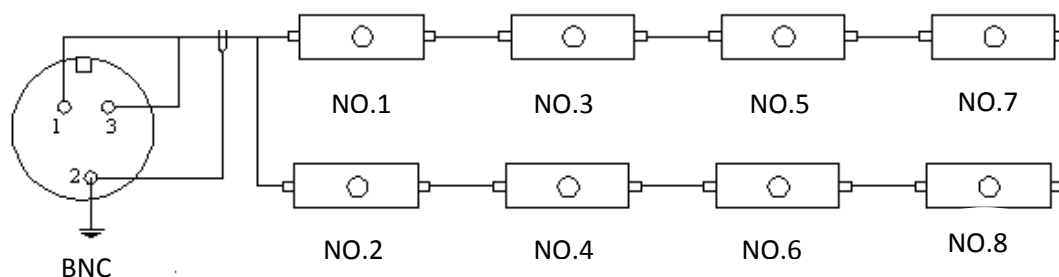

Figure 7b: Connecting diagram of spark detectors

1) Core yarn NO.1 and 3 supply DC24V for spark detectors from the host machine, and NO.2 is the shield layer. There is a bridge rectifying circuit in the inner of detector, thus there's no requirement of the polarity for power.

⚠ ATTENTION

Detectors should be connected with shielding cable with two core yarn.

2) Since the signal is transmitted via the power carrier, the connection between the detectors can adopt to the practical situation flexibly. Figure 7a and 7b show such typical connections. The connection principal is that the shorter the distance between the host machine and the detector is, the better the connection is.

3. Working principle

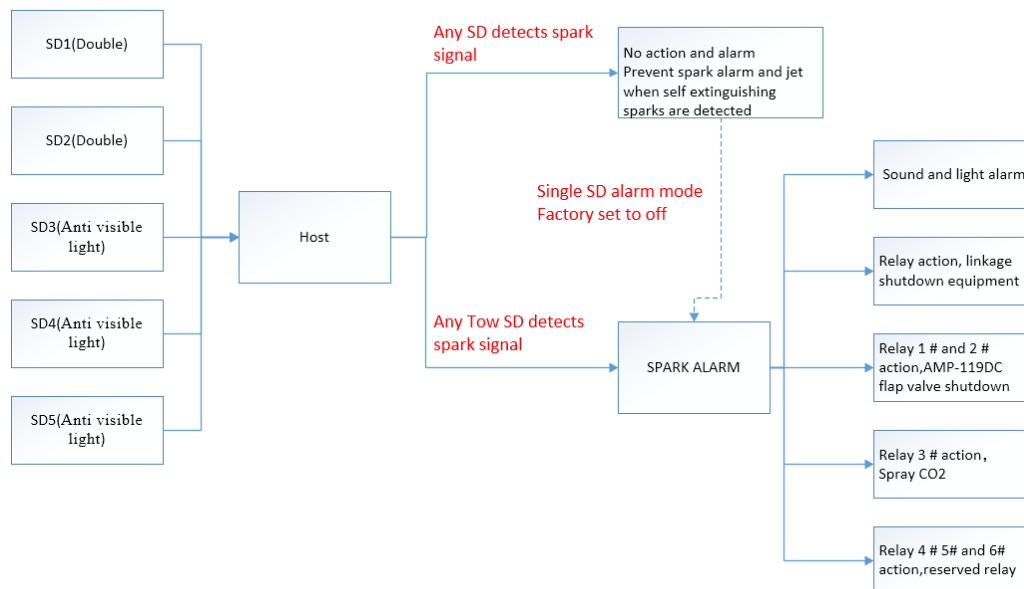

Figure 8: Diagram of working principle

This system is equipped with two sets of 119D-SDS spark detectors (detector codes are SD1 and SD2) and three 119D-SDA visible light spark detectors (detector codes are SD3 to SD5).

When any one of the five spark detectors detects a spark, and within five minutes, any of the other four spark detectors detects a spark, it is judged as a spark alarm. The relay acts, the sound and light alarm opens, the flap valve closed, and the extinguisher sprays out; If no other spark

detector alarms occur within five minutes, the device remains in normal working condition.

When the device is set to single detector alarm mode (see Chapter 2.2 for details), if any detector detects a spark, it is judged as a spark alarm. The relay acts, the sound and light alarm is activated, the flap valve is closed, and the extinguisher sprayed out.

4. Grounding and safety

- 1) All the units must be grounded directly to a common ground terminal according to the safety standard of local government.
- 2) This equipment needs to be separately grounded and it is prohibited to be grounded together with others. It is suggested that the grounded wire be as short as possible.
- 3) While overhauling, please first shut down the power supply and interrupt the compressed air supply.
- 4) After the spark alarm, the power supply should be immediately turned off before extinguishing the fire.
- 5) Spark alarm tests or maintenance that require climbing must be carried out safely and with at least two people involved.

C. Debugging and usage maintenance

1. Indicative and adjustable parameter of the control panel

1.1 Displays of the panel

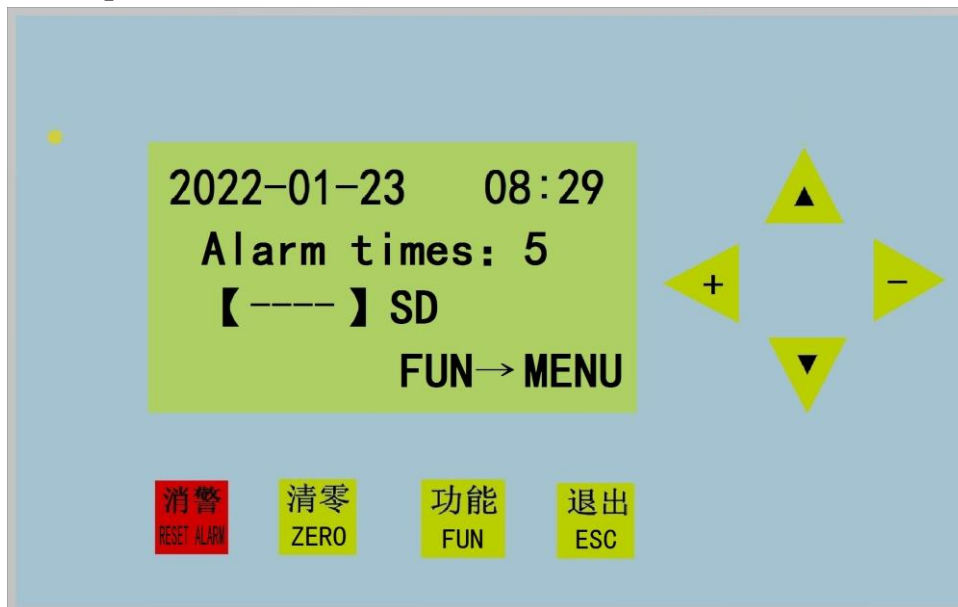

Figure 9: Diagram of control panel and main page

If the LED is always on, it means that the device has been powered on to the normal working state. If the LED flashes, it means that there is new alarm information. Press the "ALARM RESET" key to restore the original state.

Displays in panel	Meanings
2022-01-23 08:29	On Jan.23 th , Year 2022, 08:29 AM
Alarm times:5	There are 5 alarm messages
【----】SD	【】 shows the address of alarming detector
FUN→MENU	① Indicates you press the key 'FUN' to shift the main page to parameter settings. ② 'Locked' will be appearance when the keyboard locked.

Table 2: messages display in panel on Figure 6

1.2 The fire alarm page

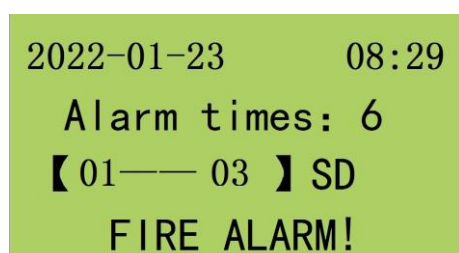

Figure 10a: Display of dual detector spark alarm

Figure 10b: Display of single detector spark alarm

When an alarm occurs, the LED indicator light flashes and the page in Figure 10a appears, indicating that at 8:29 am on January 23, 2022, spark alarm occurs, and the alarm spark detectors number are SD1 and SD3 in sequence, and the current cumulative number of alarms is 6; The page in Figure 10b represents that at 8:29 am on January 23, 2022, spark alarm occurs, and the alarm spark detector number is SD3, and the current cumulative number of alarms is 6;

Press the key “ALARM RESET”, alarm page will turn to working page.

1.3 The description of keys

Enter into parameter setting page by pressing “FUN+▲” key.

- 1) “RESET ALARM” :Reset fire alarm key. After pressing the key, the alarm status will be eliminated and the instrument returns to the normal working state..
- 2) “ZERO” Counter clear key.. To clear alarm records in the ‘Alarm record’, press the key ‘FUN’ as well as ‘zero’.
- 3) “FUN” Function key. The key is used to switch the menu page (refer Figure13). If the keyboard is locked, you can enter the menu page by pressing the ‘FUN’ and ‘▲’ keys simultaneously.
- 4) “ESC” Exit key. After pressing the key, you will return to the main page.
- 5) “▲” Up key, “▼” Down key, “+” Left key, “-” Right key, These keys have the functions of shifting parameter settings and changing the data.

2. Parameter setting

After pressing the key 'FUN' on the main page, you will turn to the page of parameter settings.

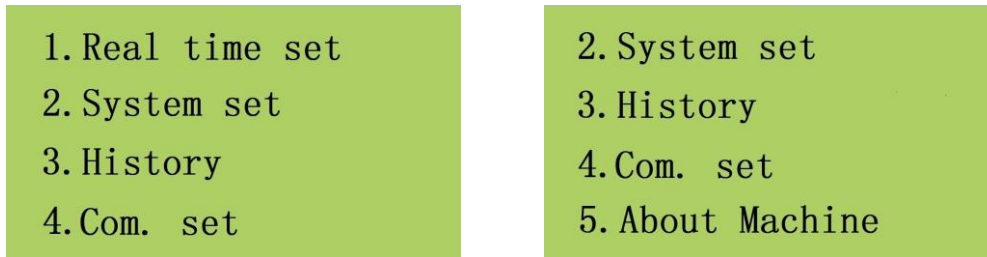

Figure 11: Parameter settings

When the cursor is flashing in the '1.Real time set' item, press the key 'FUN' to enter into time settings, use the key '▲ , ▼' to switch positions of the cursor. Press the key 'FUN' entering into the screen where the cursor stayed.

2.1 Real time set

Enter into the time setting menu page, press '▲, ▼' turning to switch among the month, date, year, hour, minute. Through pressing the key '+, -', we can change the value of the data. After finishing the setting of the time, press the 'ESC' key to return to the main page.

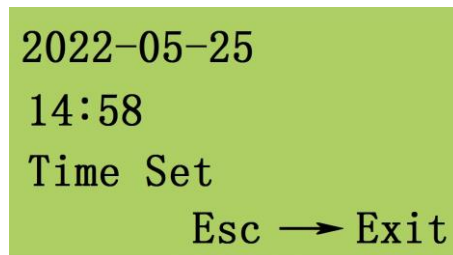

Figure 12: Time settings menu

2.2 System set

After entering into the 'System set' page, press the key '▲, ▼' to shift between the two items.

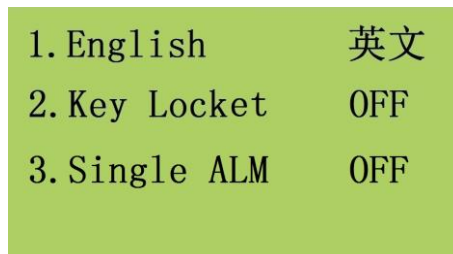

Figure 12: System settings

1) The cursor is flashing in the '1. CHINESE 中文' item, shows that we can choose according to the language, press '+, -', then we can select the system's language between Chinese and English.

2) The cursor is flashing in the '2.key locket' item, shows that we can lock the keyboard now,

pressing the key '+ , -' to select 'ON' or 'OFF'.

3) The cursor is flashing in the '3.single ALM' item, shows that the alarm mode of the spark detector can be set: press the '+, -'keys to switch the detector alarm 'ON' and 'OFF'. 'OFF'indicates that any two spark detectors have detected a spark signal and the device will give a spark alarm; 'ON'indicates that any spark detector detects a spark signal, the device triggers a spark alarm, and the device is set to OFF at the factory.

2.3 History

In the parameter setting, when the cursor flashes at ' 3.History' item, you can press the key 'FUN' to enter into the History inquiring page, and then read the recent records of spark alarming.

Date	Time
22-04-09	15:14
Count Alarm:	05
【 01—— 03 】SD	→

Figure 13: Alarm record

Count alarm: 05 "represents the fifth alarm record of the equipment; 22-04-09 15:14: Record the spark alarm time as 15:14 on April 9, 2022; [01——03] SD "indicates that the alarm spark detectors number are SD1 and SD3 in sequence; Press '-' Press the key to scroll through the previous fire alarm records; press the key 'Esc' to return the main work page.

2.4 Communication

There is a RS-485 communication interface on the control board.(P3 terminal)

When the cursor flashes in '4.com set' item in parameter setting menu, you can enter into to the Communication setting page by press 'FUN' .

1. Com. addss	01
2. Baudrate	9600
3. Modbus network	
	(8, N, 2 RTU)

Figure 14: Communication

1) Press '+, -' can select the communication address which can be set from No1 to No.32. The default communication address is 1.

2) RS-485 can be set up to communicate on Modbus networks,the baud rate can be selected

between 9600bit/s, 19200bit/s, and 38400bit/s. The initial setting is 9600bit/s. The communication protocol uses Modbus RTU mode, protocol (8, N, 2, RTU).

2.5 About machine page

When the cursor flashes in “5. About Machine” item in parameter setting menu, you can enter into to the About machine page by press ‘FUN’ get the equipment model, production date and version information.

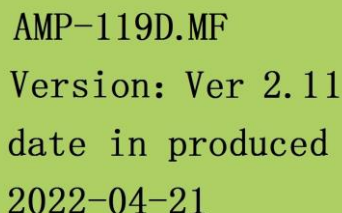

```
AMP-119D.MF
Version: Ver 2.11
date in produced
2022-04-21
```

Figure15. About machine page

3. Fire alarm simulation test

1) Remove the spark detector from the sealed pipeline and irradiate it with a flashlight. The controller can produce normal action (as the tungsten wire in the flashlight's small ball is a heating element that contains infrared radiation). During the action, the sound and light alarm needs to be manually pressed to release the alarm.

2) During the normal use, if fire alarm happens, the fan and other machinery's operation cannot be started until the cause is found out. Occasionally although the spark is small and can be out by itself, we should also stop for not less than half an hour and we cannot start until it is inspected and the safety can be assured.

ATTENTION

① The spark alarm function should be checked regularly with simulation test to assure that they are in the good working status. It is suggested that the test be carried out at least once every two weeks.

② The dust and waste on the surface of lens in spark detectors must be regularly checked and cleaned.

③ If the system is equipped with a diverter, it also needed regular check and maintenance to avoid turning plate transposition or fuzzy edge.

D. Communication

1. Communication baud rate and address setting

Parameter	Setting range	Default value
Baud rate	b1 (9600bit/s) b2 (19200 bit/s) b3 (38400 bit/s)	b1, 9600
Communication address	d1~d32	d1

Table3. Communication parameter setting

Note: The default baudrate is 9600, communication address is 1.

2. Communication protocol

2.1 Communication format

11-bit character frame (8,N,2 for RTU)

Start bit	0	1	2	3	4	5	6	7	Stop bit	Stop bit
-----------	---	---	---	---	---	---	---	---	----------	----------

2.2 Communication protocol RTU mode

START	Keep no input signal greater than or equal to 10ms
address	Communication address
Function	Function code
DATA (n-1)	Contents of data : n×8-bit data n≤40
.....	
DATA 0	
CRC CHK Low	CRC check sum
CRC CHK High	16-bit CRC check code consists of two 8-bit combinations
END	Keep no input signal greater than or equal to 10ms

2.3 Local communication protocol parameters address definition

a) function code 03

Register data read write (function code 03,)	0001H	Status register
	0002H	Alarm spark detector No
	0003H	Spark alarm count
	0004H	Software version
	0005H	Communication address
	0006H	Baud rate

b) function code 01

Coil data write (function code 01)	Bit1	—
	Bit2	Chinese/English menu
	Bit3	—
	Bit4	—

	Bit5	——
	Bit9	Fire alarm
	Bit15	——

c) function code 05

Coil data write (function code 05)	Bit1	——
	Bit2	——
	Bit3	——
	Bit9	Fire alarm

Force coil bit 9 to ON state

Function: Reset fire alarm/ Reset part of the fault alarm content

E. Troubleshooting

Fault phenomenon	Fault analysis	Checkpoint
The panel does not light up	<ol style="list-style-type: none"> 1. Power supply circuit 2. The motherboard is damaged or the power transformer is damaged 3. The plug on the circuit board is loose 	<ol style="list-style-type: none"> 1. AC220V power input 2. Main board output voltage and transformer output voltage 3. Is the wiring or plug loose on the plug
Spark detector false alarm	<ol style="list-style-type: none"> 1. Sparks do occur frequently 2. Light interference detection area 3. Detector damage 	<ol style="list-style-type: none"> 1. Determine if there is a real spark false alarm fault 2. Determine whether there is light interference in the detection area, and ensure that the detector operates in a dark environment 3. Replace the spark detector
Spark detector does not alarm	<ol style="list-style-type: none"> 1. Interruption or short circuit of line connection; 2. The motherboard is damaged; The spark detector is damaged. 	<ol style="list-style-type: none"> 1. Measure whether the 24V voltage at the spark detector end is normal; 2. Is the indicator light of the spark detector turning from green to red during the alarm.
The host alarm code and spark detector code are inconsistent	<ol style="list-style-type: none"> 1. The signal wire of the spark detector is parallel to or bundled with other cables to generate signal coupling; 2. The spark detector is damaged. 	<ol style="list-style-type: none"> 1. Make a short wire and directly connect the spark detector to the host to see if the decoding is correct; 2. Change the encoding of the spark detector and then alarm to see the decoding status.
The spark detector detects a spark and provides an audible and visual alarm, but there is no output relay signal	<ol style="list-style-type: none"> 1. The relay is damaged; 2. The control motherboard is damaged; 3. The relay output setting is incorrect. 	<ol style="list-style-type: none"> 1. Measure the normally open and normally closed points of relay contacts; 2. Check if the LED light on the upper end of the corresponding relay is on; 3. Check the host settings menu.



Add: No. 16, Xihuan 2nd Road, Jintan District, Changzhou, Jiangsu, China

Web: www.ampecn.com E-mail: ampecn@ampecn.com

Phone: 86-519-82612300 Fax: 86-519-82616555